

960 MACHINABLE ALUMINA

Ultra Hi Temp. - Use Up To 3000°F

RESCOR 960 is a 96% Alumina Machinable Ceramic.

Usable to 3000°F

960 Machinable Alumina Ceramic is manufactured from high purity Alumina by a unique process.

Machining can be accomplished with conventional tooling on standard shop equipment.

No heat treatment is required.

RESCOR 960 Machinable Alumina can be used continuously to temperatures of 3000°F, providing the convenience and economy of in house capability for Alumina parts.

The chemical, thermal and electrical properties of RESCOR 960 are equivalent to standard High Alumina ceramics.

RESCOR 960 is ideal for applications in electrical, electronic, metallurgical, fixtures and vacuum industries.

RESCOR 960 hardener is a clear ceramic impregnant which, cures at 600°F.

Use 960 hardener to harden and increases the wear resistance of the 960 surface, when require.

RESCOR 961 a fully dense, zero porosity High Strength Alumina is now available in tubes, rods, bars and for custom parts (see page 20).

- **Electrical Components**
- **Insulators**
- **Prototypes**
- **Brazing Fixtures**
- **Vacuum Fixtures**
- **R. F. Heating Fixtures**
- **Supports**

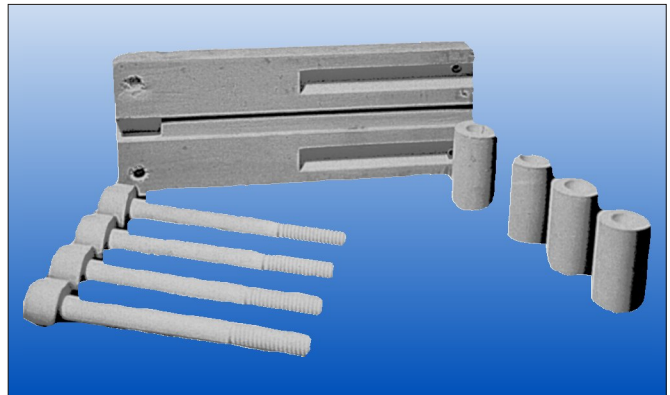

Precision Components, Tooling and Fixturing

Max Operating Temp °F	3000	Dielectric Strength (volts/ mil)	200
Melting Point °F	3400	Volume Resistivity (ohm/cm)	10 ¹⁵
Compressive Strength (psi)	60,000	Loss Factor (1MHz)	0.0016
Flexural Strength (psi)	38,000	Dielectric Constant (1MHz)	9
Thermal Expansion (x10 ⁻⁶ /°F)	4.3	Thermal Conductivity*	40
Density (gm/cc)	3.8		*BTU in / Hr °F Ft ²

Cat. No. Rod Stock Sizes

- 960-1 1/4" x 6"
- 960-3 1/2" x 12"
- 960-5 3/4" x 12"
- 960-7 1" x 12"
- 960-12 1.5" x 12"
- 960-9 2" x 12"
- 960-10 2.5" x 12"

Cat. No. Rod Stock Sizes

- 960-11 3" x 12"
- 960-13 3.5" x 12"

Plate Stock Sizes

- 960-14 1/4" x 6" x 6"
- 960-15 1/2" x 6" x 6"
- 960-16 3/4" x 6" x 6"
- 960H Hardener Pint
- 960-K Machinable Alumina Trial Kit

Typical Tolerances are -0.005" to +0.030"



COTRONICS CORPORATION

www.cotronics.com

Send Prints For Custom Machining Services

(718) 646-7996 Fax (718) 646-3028 3379 Shore Parkway, Brooklyn, N.Y. 11235